

# GRK DECK ELITE

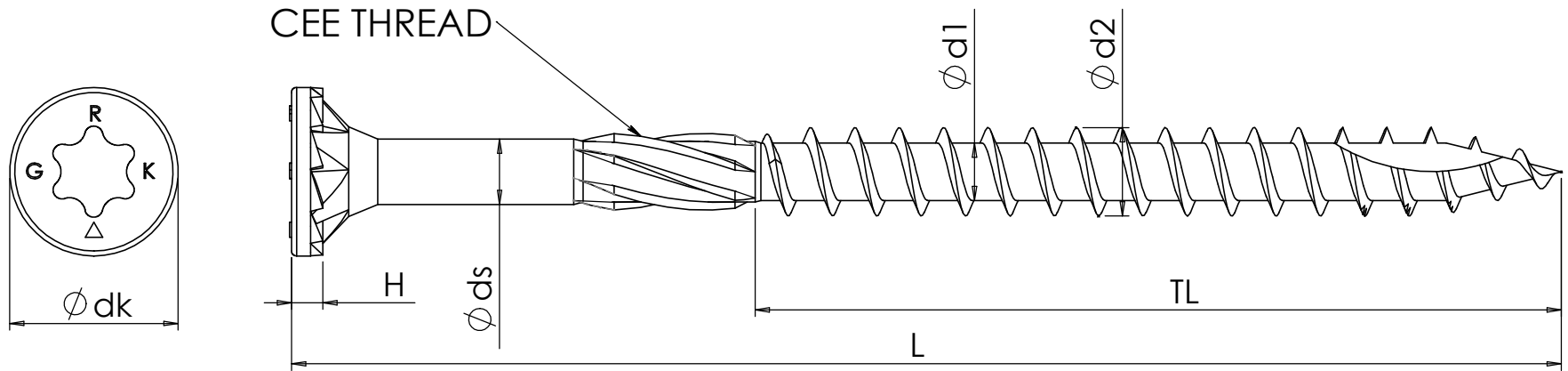

SIZE (Dia)	Head diameter (dk)	Head height (H)	Shank diameter (ds)	Minor diameter (d1)	Major diameter (d2)
# 8	0.300	0.050	0.114	0.104	0.155
# 9	0.330	0.063	0.128	0.110	0.173



SIZE(Length)	Length (L)	Thread length (TL)
1-5/8	1.625	1.00
2"	2.000	1.30
2-1/2"	2.500	1.58
3"	3.000	1.45



**NOTES:**

1. Dimensions are in inches without any manufacturing tolerance.
2. No CEE thread on 1-5/8" long fasteners.

**PROPRIETARY AND CONFIDENTIAL**  
 THE INFORMATION CONTAINED IN THIS DRAWING IS THE SOLE PROPERTY OF Illinois Tool Works Inc. ANY REPRODUCTION IN PART OR AS A WHOLE WITHOUT THE WRITTEN PERMISSION OF Illinois Tool Works Inc. IS PROHIBITED.

Distribution Record	Headmark	NAME	DATE	  155 Harlem Ave. Glenview, IL 60025
ITW		D. Hamon	April 24, 2020	
		CHECKED		
		ENG APPR.		
		MFG APPR.		
		Q.A.		DWG. NO. Sales Support Deck Elite Screw
				REV. <b>0</b> Deck Elite SHEET 1 OF 1